

Optic Rotary Incremental Encoder

- 58 mm case diameter
- 100 - 200 - 360 - 400 - 500 - 600- 720 - 1000 - 1024
1800 - 2000 - 2048 - 2500 - 3600 - 4000 - 4096 - 5000 ppr.
- Push-Pull, TTL Linedriver and HTL Linedriver outputs
- Shaft diameter 6 - 8 - 10 mm
- 3500 rpm max.

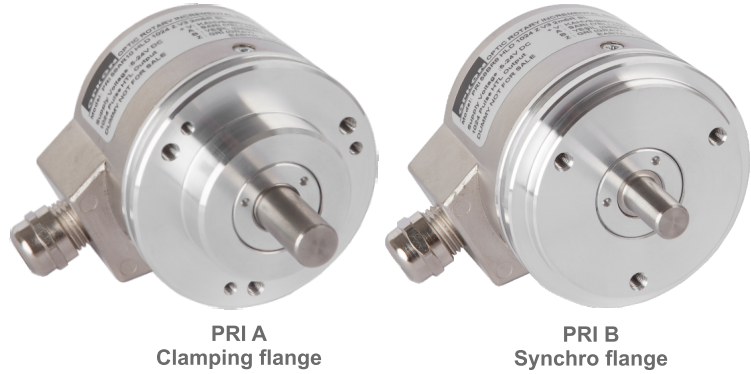

PRI A
Clamping flange

PRI B
Synchro flange

Technical Specifications

Resolution	100 to 5000 ppr.
Output Channels	A,B,Z or A, \bar{A} , B, \bar{B} , Z, \bar{Z}
Output Type	Push-Pull, TTL Linedriver, HTL Linedriver
Supply Voltage	5V DC or 8-24V DC or 5-24V DC
Power Consumption (without load)	< 40 mA (24 VDC)
Cable	2.5m (Standard) 5 Wire + Shield for Push-Pull 2.5m (Standard) 8 Wire + Shield for Linedriver
Max. Permissible Shaft Loading Radial	60 N
Axial	40 N
Max. Speed	3.500 rpm
Shaft Diameter	Ø6 - 8 - 10 mm
Shaft Material	Stainless Steel
Case Diameter	Ø58 mm
Case Material	Aluminium and Painted Steel
IP Degree	IP 54
Operating Temperature	-20°C ... +80°C
Storage Temperature	-30°C ... +90°C

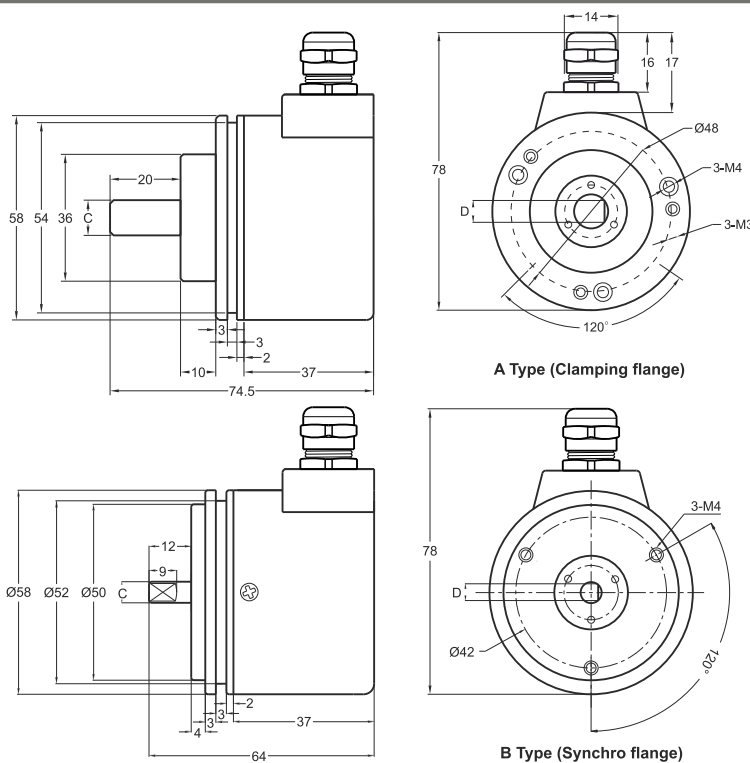

Push-Pull Cable Output

- +V : Brown
- 0V : White
- GND : Shield
- Ch A : Yellow
- Ch B : Green
- Ch Z : Gray

TTL - HTL Linedriver Cable Output

- +V : Brown
- 0V : White
- GND : Shield
- Ch A : Yellow
- Ch B : Green
- Ch Z : Gray
- Ch A inv.: Blue
- Ch B inv.: Red
- Ch Z inv.: Ping

PRI 58	AR (shaft)		BR (shaft)	
	C	D	C	D
	Ø6mm	5mm	Ø6mm	5mm
Ø8mm	7mm	Ø8mm	7mm	
Ø10mm	9mm	Ø10mm	9mm	

Model	Case Diameter	Case Type	Shaft Diameter	Output Type	Resolution	Output Channels	Supply Voltage	Connector / Cable	Cable Output
(example) PRI	58	A	R8	HLD	1024	Z	V2	2M5	R
PRI	58mm	A : Clamping flange B : Synchro flange	R6 : 6mm R8 : 8mm R10 : 10mm	LTP : Push-Pull LD : TTL Linedriver HLD : HTL Linedriver	100 ... 5000 ppr.	Z : A, B, Z B : A, B	V1 : 5V DC V2 : 8-24V DC V3 : 5-24V DC	2M5 : 2,5 meter cable 5M : 5 meter cable 8M : 8 meter cable 10M : 10 meter cable C12 : 12 pin connector	R : Radial